



**INSTRUCTION
MANUAL**

THORENS TD 150/II

INSTRUCTION MANUAL



THORENS
TD 150/II

Contents

| | |
|--|----|
| 1. INTRODUCTION | 4 |
| 2. UNPACKING | 4 |
| 3. AC MAINS CONNECTION | 5 |
| 4. CARTRIDGE INSTALLATION AND CONNECTION | 6 |
| 5. SPECIAL VERSIONS OF THE TD 150/II | 11 |
| 6. MAINTENANCE | 12 |

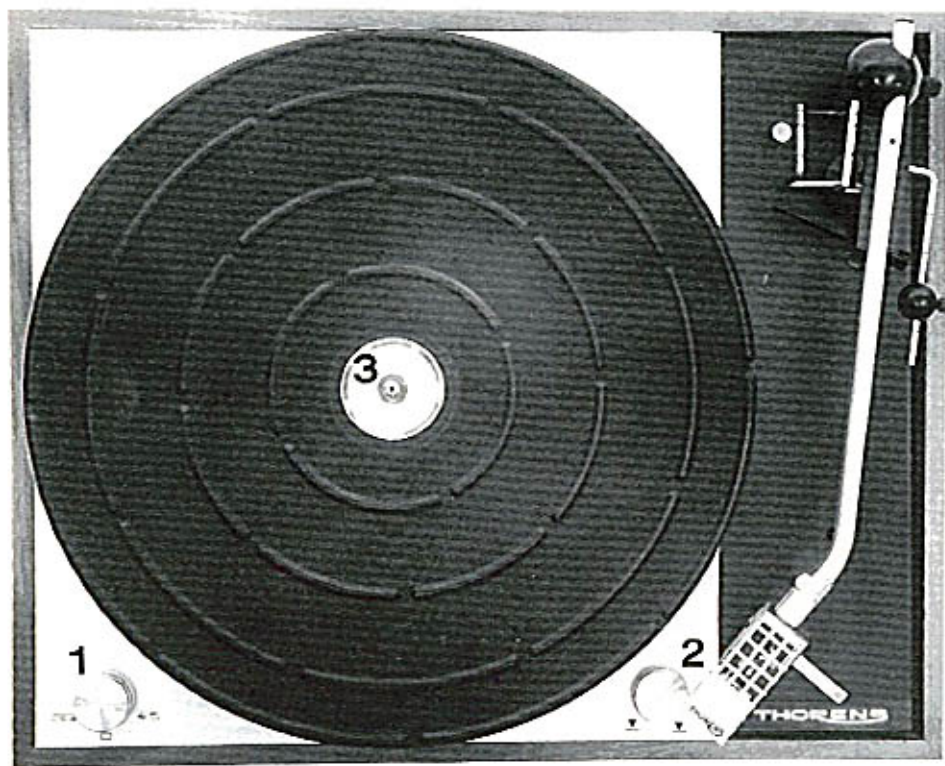

Fig. 1

▼ tone arm lifted

▼ play' position

Operation summary

1. Connect the turntable to the AC mains power supply. Check for the correct voltage.

For adjustment to another voltage, please refer to chapter 3.

2. Switch on the unit and select speed ($33\frac{1}{3}$ or 45 rpm) by means of the double function knob (1) on the left hand side of the unit

3. The adaptor in the center of the turntable platter (3) may be turned over for adjustment in order to play records with either large or small center hole.

4. Tone arm lowering device

When turning the control knob on the right hand side of the unit (2) the tone arm is lowered onto the record or lifted from the record.

4. CARTRIDGE INSTALLATION AND CONNECTION

If a cartridge has been purchased which has been professionally premounted into the Thorens plug-in shell, disregard the following.

4.1. Cartridge installation

The aluminium plug-in shell TP 50 offers enough space and the necessary mounting hardware to suit any standard pick-up cartridge.

The specific mounting instructions furnished by the cartridge manufacturers should be followed EXCEPT that the screws delivered with the TD-150/II AB and A turntables must be used. (The mounting screws supplied with US cartridges are for US standards and will not fit the metric threads used on Thorens units).

4.2. Cartridge height

The cartridge height on the plug-in shell should be chosen in order to bring the stylus tip at a distance of $\frac{3}{4}$ " to $\frac{7}{8}$ " (19 to 22 mm) from the bottom of the shell. If necessary, make use of the furnished spacers.

4.3. Cartridge connections

Four separate colour coded leads are already soldered to the terminal pins in the shell:

Red — Right channel positive (hot)
Green — Right channel negative (shield)

These two leads constitute also the normal mono channel.

White — Left channel positive (hot)
Blue — Left channel negative (shield)

4.4. Pick-up output connections

The TD-150/II AB and A models are wired at the factory according to Fig. 3.

Right channel: standard male phonoconnector plug, black colour

Left channel: standard male phonoconnector plug, white colour

Ground connection:

— The unit plate and the metal part of the arm are connected in A to the shield of the right channel cable acting as a ground lead.

— The shield of the left channel cable is insulated from the base plate of the turntable and from the metal parts of the arm.

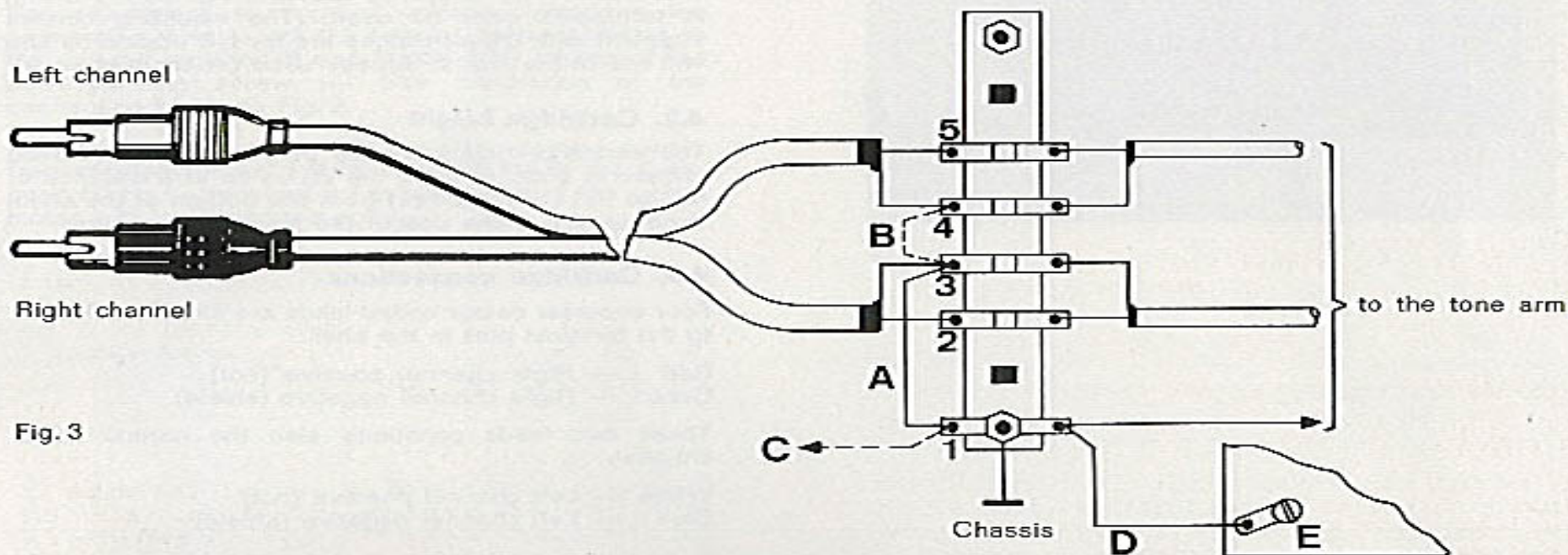

Fig. 3

The spring mounted parts of the turntable are connected to the fixed unit plate by ground lead D. Lug E should be fastened on the metal frame by the corresponding set screw of the pick-up wooden board.

If necessary for particular cartridges or amplifiers, two different wiring systems may be easily realized:

3 wire system

Connect lugs 3 and 4 on the terminal strip with a wire B; the shields of both channels are thus connected together and to the unit plate.

5 wire system

When the ground for the turntable cannot be returned to the amplifier ground through the signal carrying shieldings, the wire connecting lugs 1 and 3 should be cut at A and a separate insulated wire C connected from lug 1 to the common grounding point for the amplifiers.

Cartridge alignment

The TP 50 plug-in shell allows to adjust first the vertical tracking angle and then the stylus overhang for optimum tracking.

4.5. Vertical tracking angle

a) Loosen slightly the two screws A on both sides of the shell and small screw B (see Fig. 4).

b) Insert the shell plug in arm socket, allowing the locating pin to enter the slot. Press inward and tighten the locking nut firmly, but not more than necessary. This operation is best performed when the arm is clamped in the arm rest.

c) Bring the arm over a record (caution: take a worn record) and adjust the vertical tracking angle according to the instructions of the cartridge manufacturer.

For 15° cartridges the proper vertical tracking angle is obtained when the upper surface of the plug-in shell is horizontal.

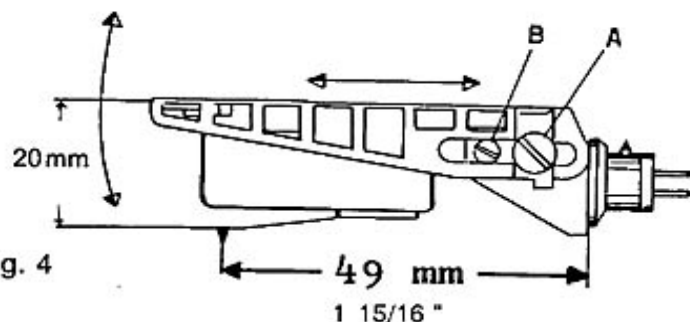

Fig. 4

Make sure that the rear of the shell cannot contact a warped record. If necessary, increase the vertical distance between the stylus tip and the bottom of the shell with the help of spacers (see No. 5.2. above).

d) Tighten small set screw B.

4.6. Stylus overhang

The optimum distance of 230 mm between stylus tip and vertical tone arm bearing is obtained when the stylus tip is at a distance of 1,15/16" (49 mm) from the rear vertical surface of the plug-in shell. See Fig. 4. Tighten the two screws A.

Important notice

The TP 50 plug-in shells for both the TD 150/Mk I and TD 150/Mk II turntables are identical, however, they have to be adjusted for a **different** stylus overhang.

So when using an older TP 50 plug-in shell for the TD 150/Mk II, the stylus overhang has to be re-adjusted as explained hereabove.

4.7. Balance and stylus force adjustment

The TP-13 A integrated pick-up arm has been designed to reach an excellent longitudinal and lateral balance simultaneously to the adjustment of the stylus force for pick-up cartridges.

For adjusting the stylus force, position the tone arm so that the stylus tip is between the arm rest and the turntable platter. The control knob for the tone arm

lowering device should be in the "play" position and the additional weight C in the position "Balance" according to Fig. 5.

Move counterweight A (Fig. 5) along the tubular arm extension until the arm assumes a horizontal position. If properly balanced, the tone arm will keep its position when slightly inclined above or below the horizontal.

Then fasten knurled screw B.

After having clamped the tone arm in the arm rest, adjust the stylus force to the requested value by means of the additional weight C.

The front edge of weight C must be in line with the desired scale division.

Each division of the scale corresponds to 0.5 gram. — See also Fig. 5.

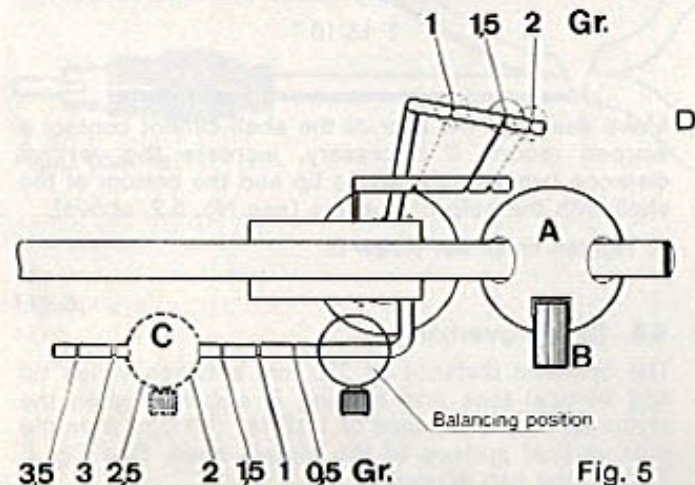

4.8. Anti-skating adjustment (D)

The adjustment has to be made corresponding to the stylus force required by the cartridge, following Fig. 5. The adjustment obtained by this method is approximative only. It is however possible to determine exactly the proper anti-skating force by using a High Fidelity test record which incorporates a tracking test. Whilst playing this part of the record, at first without anti-skating force, reduce the stylus force until distortion becomes audible. Normally it is first audible in the right channel and upon a further reduction of the stylus force, in the left channel. Adjust the anti-skating device until the distortion appears equal in both channels. The adjustment being made, increase the stylus force back to a value which guarantees a distortion free reproduction.

If a test record with a blank part (without grooves) is available, the anti-skating force may be adjusted by means of this part of the record. The anti-skating device shall be adjusted in such a way that the tone arm does neither tend to move towards the center nor to the outer edge of the record.

5. SPECIAL VERSIONS OF THE TD 150/MKII

Besides the integrated TD 150/Mk II AB turntable with tone arm TP 13 A and base (plinth), the following special versions are available upon request:

- TD 150/Mk II without tone arm and without base
- TD 150/Mk II A with tone arm TP 13 A, but without base
- TD 150/Mk II B without tone arm, but with base

The following mounting instructions apply to these special executions:

5.1. Tone arm mounting

For the TD 150/Mk II B with base, first remove the bottom cover by unscrewing the four plastic feet. From the underside loosen the four screws fastening the tone arm board to the metal frame of the unit. Consult the instructions supplied by the tone arm manufacturer and make use of the corresponding template to mark the wooden board before drilling the necessary holes.

Install the pick-up arm on the wooden board and connect it according to the instructions of the manufacturer.

Pick-up arms with an output connector and an output cable may be connected directly to the amplifier, provided this cable has a sufficient compliance. Any stiffening of the spring mount of the turntable through the pick-up leads should be avoided if best results are to be obtained. If necessary, replace the output cable by more compliant leads and connect them to the unit connecting plate. See Fig. 3. Pick-up arms without an output connector should be connected to the unit connecting plate.

Fasten the wooden board on the metal frame of the unit with the four screws.

A ground lead should connect the metal part of the arm to lug E (see Fig. 3).

Particularly heavy pick-up arms may require some adjustment of the three conical coil springs supporting the metal frame on which the wooden board is fastened. Adjust by turning the terminal nuts on the threaded studs. The outer 12" turntable should be installed for this operation.

5.2. Mounting the turntable into furniture

The TD 150/Mk II turntable should be mounted on a plywood mounting board of not less than 1/2" thickness. The mounting board should be as level as possible and its attachments very stable to minimize the transmission of floor vibrations.

Mark and cut out according to template. Fasten the unit by means of 4 screws. For hiding the edges of the turntable cover plate, which rise about 2 mm over the top surface of the panel, a frame kit (CE 15) is available.

This kit consists of 4 selfadhesive anodized aluminium bars. After removing the protecting paper the bars shall be brought into position and pressed firmly down onto the mounting board.

3. AC MAINS CONNECTION

Before connecting the unit to the mains power supply check for the correct voltage!

As supplied for USA and Canada, the turntable motor is set for 60 cycle, 100 to 120 volt operation.

For other countries, unless differently specified when ordering, the motor is set for 50 cycle, 200 to 240 volt operation.

For adjustment to another voltage, introduce the connecting wire A into the terminal corresponding to the voltage required B and fasten it by means of the corresponding screw. — See illustration of the connecting block on Fig. 2.

Adjustment to another AC mains power supply frequency — for ex. from the US 60 Hz to the European 50 Hz — requires the replacement of the whole motor with its integrated pulley.

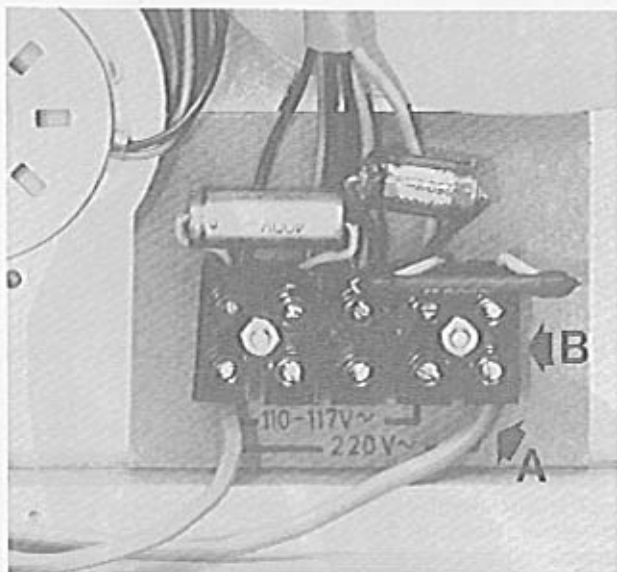

Fig. 2

THORENS

THORENS-FRANZ AG
CH 5430 Wettingen (AG)
Switzerland